

niglon

Industrial Accessories

16104 IP44 Compact Interlocking Switched Sockets

Wall Mounted



Technical Drawing

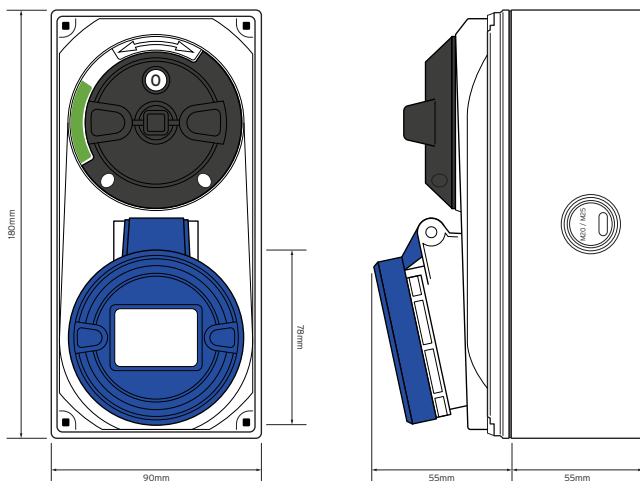

Technical Specifications

Material Composition	PA6 - PC/ABS
Amps	16A
Volts	230V
Pin Configuration	2 p + E
IP Rating	IP44
Certified	OVE & CE
Standards	BS EN 60309
Contacts	Nickel-plated
Interlock	Mechanical
Cable Entry	Rear entry M20/M25 and M25/M32 Side entry (left and right) M20/M25 Top entry M25/M32 Bottom entry M20/M25
Weight	616g
Flexible Wire Accepted	1.5-2.5mm ²
Solid Wire Accepted	1.5-4mm ²
Dimensions	180mm H x 90mm W x 110mm D

